

6.6 kW air cooled charger

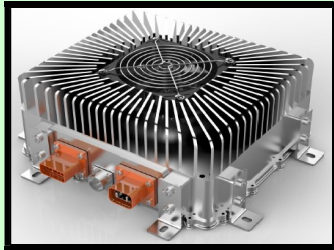

▪ Embedded charger 6.6 kW

- **Features :**
CNC machined aluminum
338 x 255 x 125 mm
13.3 x 10 x 4.9 inches
Air cooled
6 kg
IP67
-40 to +75°C
94% efficiency
- **Power input :**
6.6 kW
85-265 Vac single phase
32A
50/60 Hz
- **Power output :**
200 – 420 Vdc
0 – 20 A (controlled by CAN)
Aux : 13.8 Vdc 100W
- **Communication :**
CAN bus 250 kbs 29 bits
Cyclic frame 1 sec
Data : current, voltage, temp, ...
- **Input Protections :**
Surge protection
Short circuit protection
Over voltage protection
Under voltage protection
Input fuse current protection
- **Output Protections :**
Surge protection
Over load protection
Reverse polarity protection
Over voltage protection
Under voltage protection
Over temperature protection
Current limit protection
Output fuse current protection
- **“Interface” Options :**
CAN bus 250/500/1000 kbs 11/29 bits
Datalogger, blackbox
RS 485 / Profibus
- **Cables :**
CAN bus length : 30 cm
AC input length : 100 cm
DC output length : 100 cm

- The CHG66AC is a compact and efficient embedded charger dedicated to high voltage battery from 200V DC to 420 V DC.
- The large input capabilities (85-265 Vac) let you use it anywhere in the world. It adapts automatically to a 50 or 60 Hz network even if the frequency is not stable.
- You can place the CHG66AC in any position. The fan included is started automatically depending of the necessary power to dissipate and the ambient temperature.
- By default the CAN bus is a 11 bits 250 kbs rate with no terminal impedance, and can be adapted to your needs thanks to the “Interface” option.

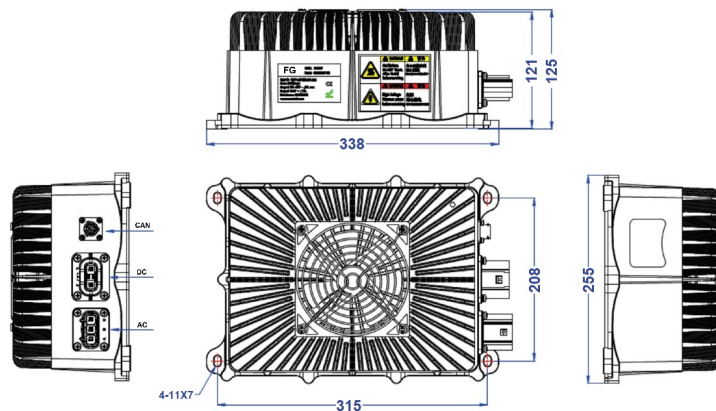

- The “Interface” option is a very compact module that is assembled to the CAN bus interface of the charger to adapt it easily to your network. If your CAN bus is a chained one and the charger is not the last device connected, you will need a special IN/OUT device to insert it easily in your wire harness.
- You want to change the baudrate or your CAN bus is a 11 bits bus? The “Interface” device will translate the CHG66AC protocol to your own. Moreover, the “Interface” includes an embedded storage memory to track the usage of your charger and store some special events like overvoltage or overtemperature.
- Most of your devices are powered by a 12V battery. What happens if this battery is empty ? Your electronic devices won’t be able to manage the charger and the battery, then no way to charge it... No problem with the CHG66AC, it includes a 13.8V 100W output to charge your 12 battery if empty and this as soon as you plug the CHG66AC to your power socket. You don’t need to have a specific charger for your 12 V battery!